

Reflex Cycling Pedal Manual

German patent and foreign patents pending

Motobicycles-36 UG
Berlin, Germany
www.motobicycles.com
support@motobicycles.com



MOTO quality

Thank you for choosing the MOTO Pedal. This manual has been designed to assist you with technical support. Should you have any questions please check this manual and if necessary contact an experienced bicycle mechanic or support@motobicycles.com.

The MOTO Pedal is manufactured completely in Germany to the highest quality requirements and assembled carefully by hand. However, should you have reason to complain please contact your bicycle dealer or the MOTO customer support team.

Safety notes

Please note that the pedals need to be driven for 50 to 100 km before the slide bearings reach their final smoothness.

For information regarding pedal maintenance, please read the instructions below or visit our website. Please note that the pedals are not designed for competition use.

We recommend lubricating the bearings with BERULUB FR 16 or equivalent lightweight, silicone-free, synthetic special grease with PTFE additives.

Construction

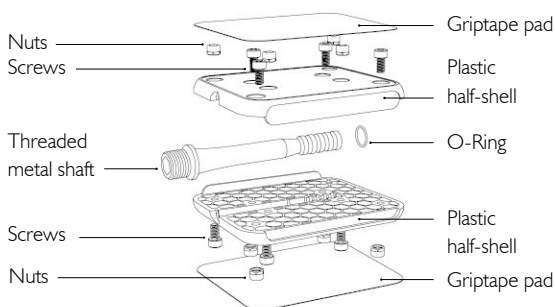

Assembly tool

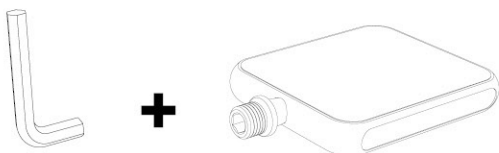

An 8 mm Allen key is needed to mount the pedals on the crank arms.

The pedal shaft terminates in an 8 mm hex socket.

Safety notes

Please read this manual properly before use and follow all the instructions carefully.

Once you have read the manual you should store it in a safe place for future reference.

You should only disassemble the pedals if you are familiar with the technology and if you have all the necessary tools at hand.

Contents

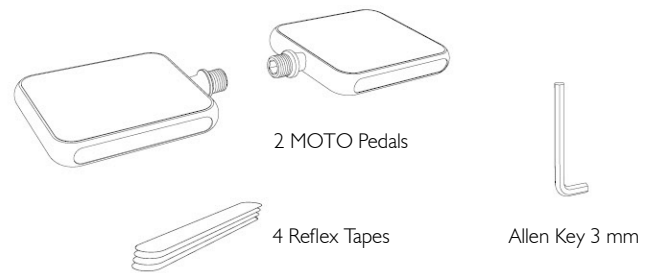

Initial adjustments

1. Stick the MOTO Reflex Tapes into the designated areas. Make sure the areas are clean.
2. Dismount the current pedals.
3. Clean the crank thoroughly, especially the thread of the pedal crank arm.

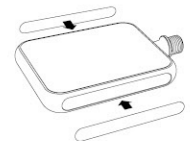

Fastening

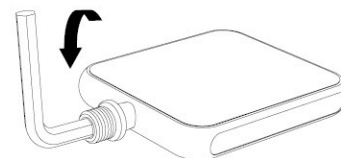

When mounting the pedal, please follow the installation instructions and the suggested torque strength given by the crank arm manufacturer!

Left pedal

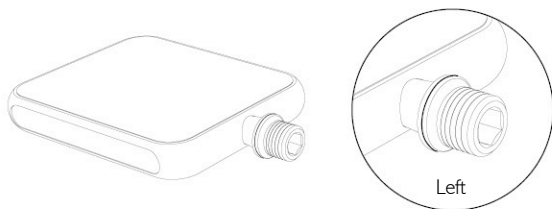

The left pedal is further identifiable by a groove / letter on the pedal collar.

Right pedal

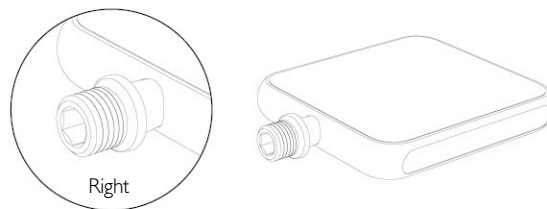

Attention! The right pedal has a right hand thread and the left pedal has a left hand thread at the pedal shaft for mounting on the crank arm.

Maintenance and care

To maintain optimal functionality of the pedals, they should be serviced every few hundred kilometers. This is done in a few simple steps and takes less than 5 minutes. To allow servicing if required, the Griptape pads are designed to be reused several times according to the state of their wearout.

1. Remove Griptape (see diagram to the right)

Heat Griptape with a hair dryer for a few seconds and remove it carefully.

2. Separate half-shells

Use the Allen key 3mm, included in the package to unscrew the half-shells.

3. Grease pedal shaft

Clean and grease pedal shaft sufficiently. We recommend lubricating the slide bearings with BERULUB FR 16 or equivalent lightweight, silicone-free, synthetic special grease with PTFE additives.

4. Tighten half-shells (see diagram to the right)

Make sure the O-ring is fitted into the designated grooves of the half-shells to prevent damage. Tighten the screws of the plastic half-shells with a torque of 120-150 Ncm. You can use the Allen key, included in the package.

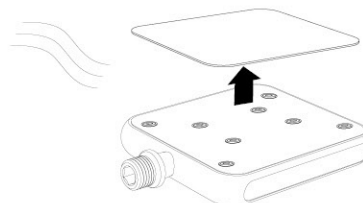

Apply heat with a hair dryer in order to remove Griptape.

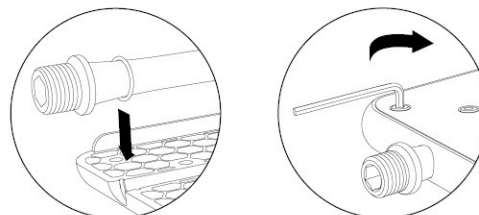

Fitting O-ring into designated grooves and tightening half-shells.

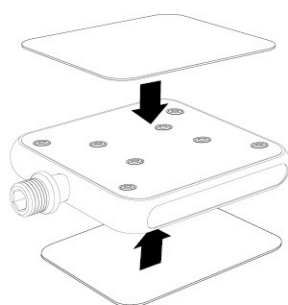

5. Apply Griptape

Stick on new or used MOTO Griptape pads on the top and bottom sides of the pedals.

Pedal width-adjustment

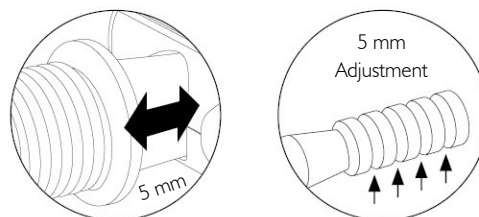

Distance between platform and crank arm can be extended or reduced by 5 mm. To adjust pedal width, unscrew half-shells and change position of the pedal shaft; see also maintenance. This provides additional space for large shoes.

Slight clicking

If the pedals develop a slight clicking sound after intensive use, this indicates that the bearings should be retightened. Please proceed as described in maintenance.

Find more useful hints at www.motobicycles.com/faq-en.html